

Series 27 Dual Column Height Adjustable Desk Assembly and Use Instructions

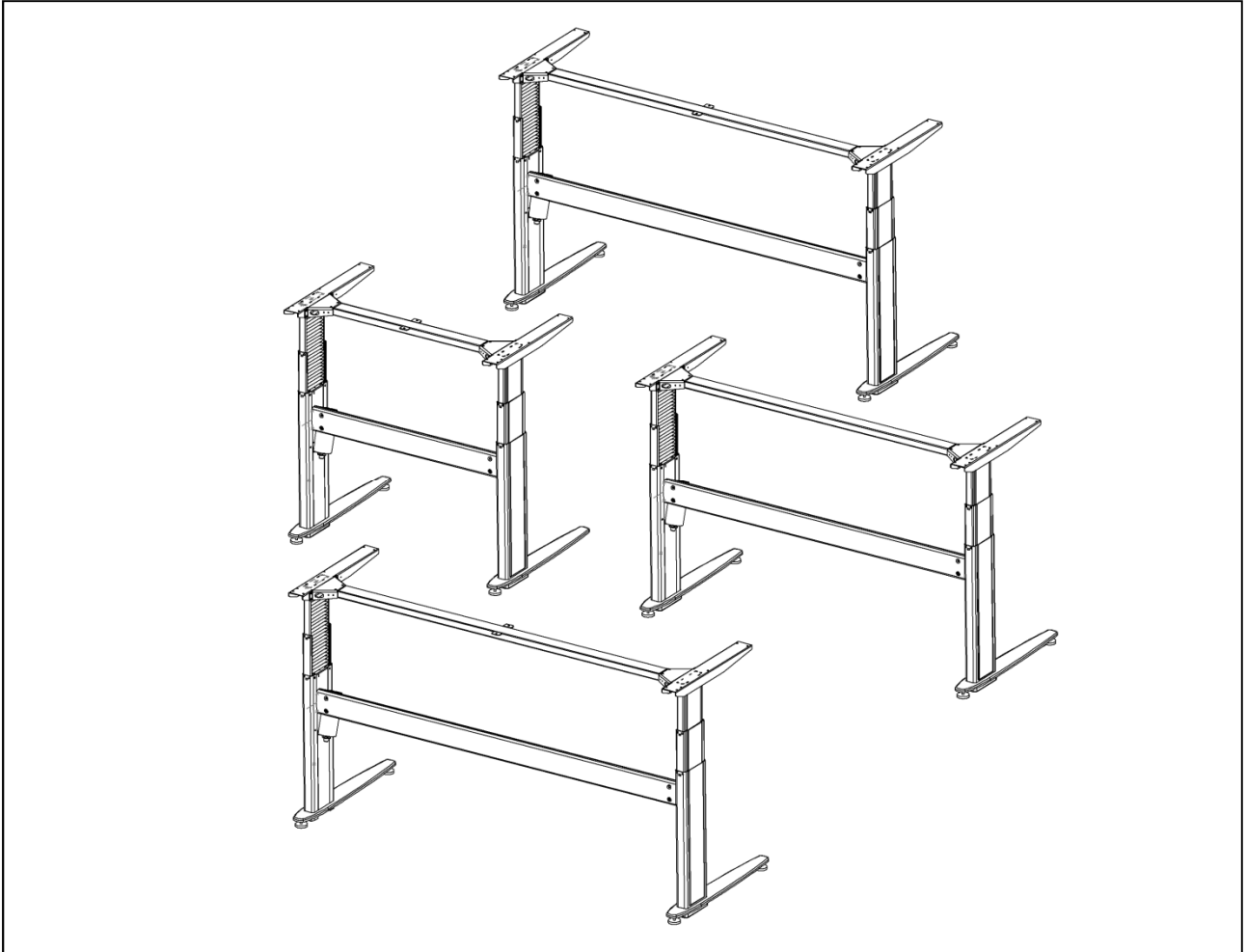

DIRECTIONS FOR USE / ASSEMBLING

EN



WARNING

WARNING: FAILURE TO COMPLY WITH OR OBSERVE ALL ASSEMBLY, SAFETY AND OPERATION INSTRUCTIONS AND WARNINGS REGARDING THE USE OF THIS PRODUCT MAY RESULT IN SERIOUS BODILY INJURY.

IMPORTANT NOTES!

Prior to installment, use and maintenance of the table frame, any installer and any user of the table must study this assembly and operation manual carefully, so as to gain a complete understanding of its contents.

TABLE OF CONTENT

1. SAFETY AND WARNINGS
2. USAGE
3. SET UP AND INSTALLATION
4. OPERATION
5. MAINTENANCE AND DEFECTS
6. TECHNICAL DATA
7. PARTS
8. ASSEMBLY DIRECTIONS
9. DECLARATION OF CONFORMITY

1. SAFETY AND WARNINGS

- This table complies with the prescribed safety regulations. Inappropriate use may cause damage to persons and table.
- Please read the operation manual prior to start using the table. It provides you with important information about safety, use, installation and maintenance of the table, and thus protecting you and your children and avoiding damage on the table.
- Please guard this operation manual and pass it on to any future owner!

2. USAGE

- The electromotive, height-adjustable tables are designed for workstations in dry work environments only (0-40°C; 20-90% relative humidity). The table height is infinitely adjustable, so that it can be set to the most ergonomically suitable working level.
- They have not been designed for other purposes than those included in this manual, e.g. they are not to be used in areas of high humidity or dampness, nor for lifting people. Any other use is at one's own risk!
- **Do not crawl, lie or move around under the table frame, and do not sit or stand on the table frame.**
- **CHILDREN should only use the table when supervised by adults.**
- **Liability:** The manufacturer accepts under no circumstances warranty claims or liability claims for damages arising from improper use or handling of the table frame other than that described in this operation manual.

3. SET UP AND INSTALLATION

When the table has been assembled (see assembly directions in CHAPTER 8) the adjustable feet are installed so that the table is level and does not shift. Then the table is connected to the 100-240 VAC outlet and the table is ready for use.

- Make sure that no cables can get jammed.
- Place the table in a safe distance from window frames, radiators, furniture etc. so that people do not get stuck.
- Do not place any objects above 16-15/16" (43 cm) underneath the table.
- When moving the table after it has been assembled, the table top needs to be removed. The table CANNOT be lifted by the tabletop.

4. OPERATION

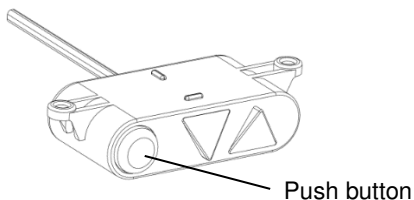

UP/DOWN operation:

Push button and UP or DOWN button must be pressed SIMULTANEOUSLY.

5. MAINTENANCE AND DEFECTS

- The table does not require any maintenance by usage as described in chapter 2 in the directions for use.
- The table is only to be maintained with a wrung cloth.
- In the event of the occurrence of jarring sounds during operation, STOP using the table and please contact the dealer.

6. TECHNICAL DATA

Frame, materials:	Steel, powder lacquered
Weights:	~ 57-66 lbs. (26-30 kg) depends on frame width.
W	35"-78" (89-200cm) depends on frame width.
D	23"-38" (59-100cm) , depends on top shape.
H (frame)	~21"-47" (54-119cm)
V (speed)	~1.2"/ sec. (32mm/sec.), depends on load
F_{MAX} = Max. Load on frame:	220 lbs. (100 kg)
Duty cycle:	10% by 50% of max load on frame or max 2 min. continuously
Operation:	Rocker switches
Voltage:	100-240 VAC / 50/60Hz
Standby Consumption:	< 0,5 Watt
Above specifications may vary depending on local temperature, humidity and input voltage.	

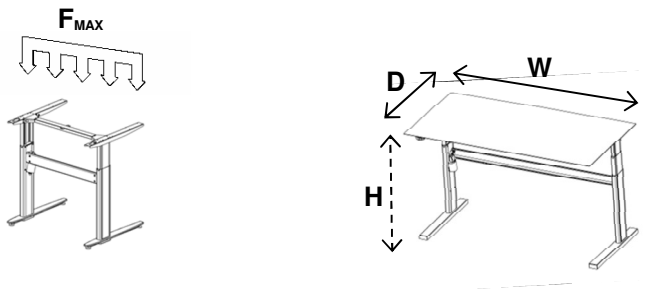

7. PARTS

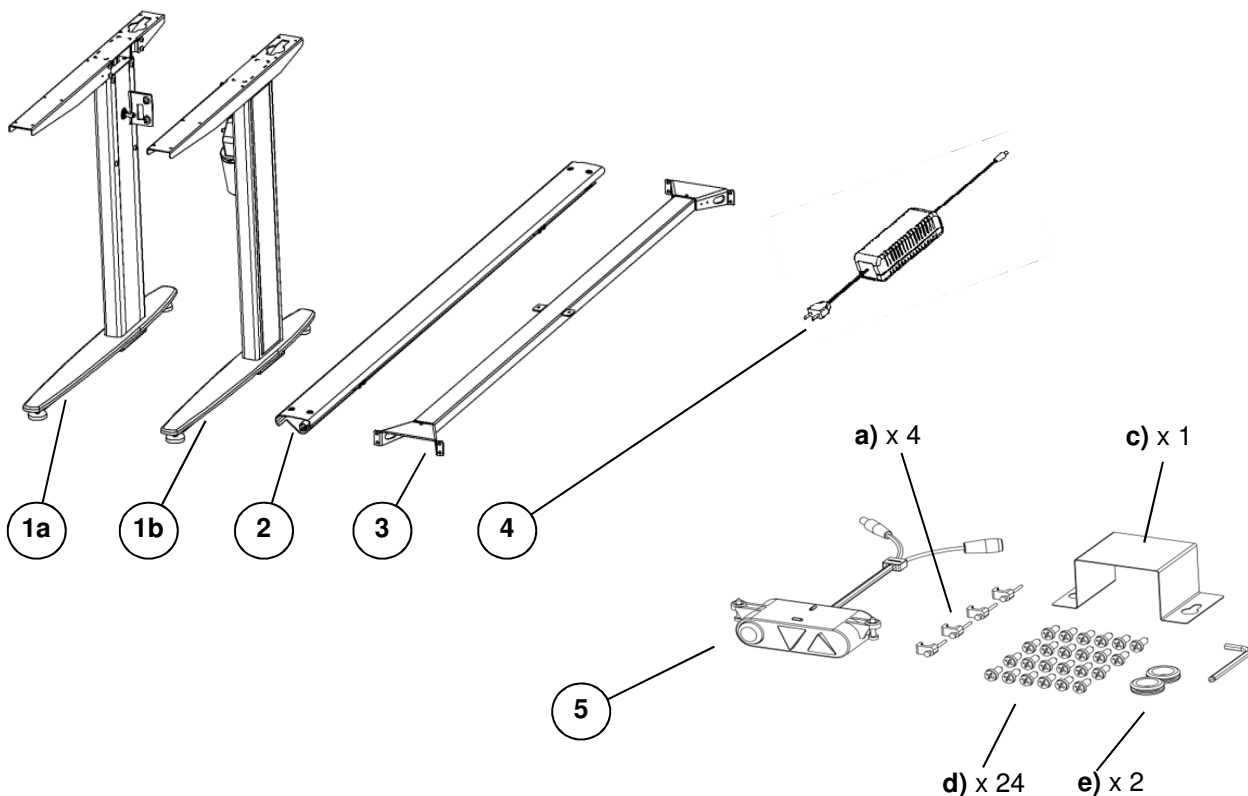

8. ASSEMBLY DIRECTIONS

1

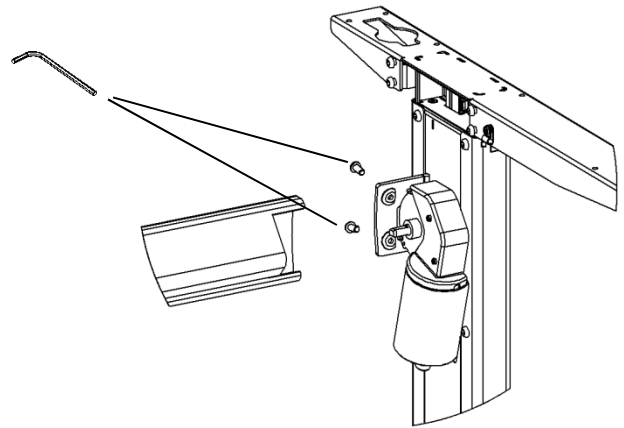
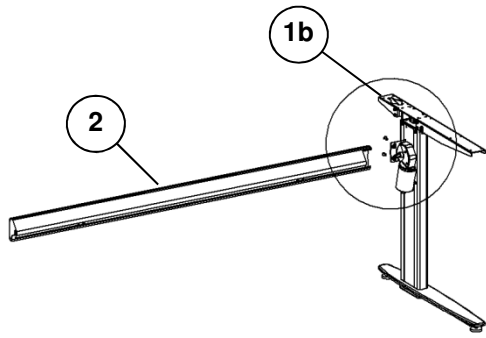

2

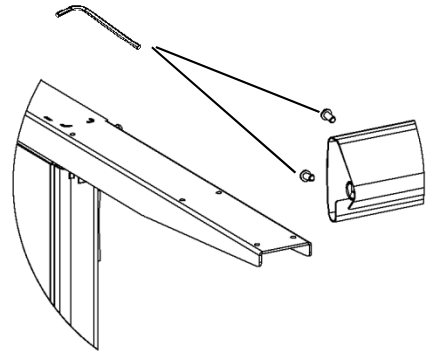
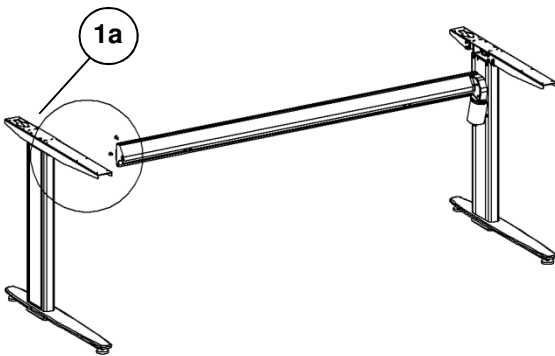

3

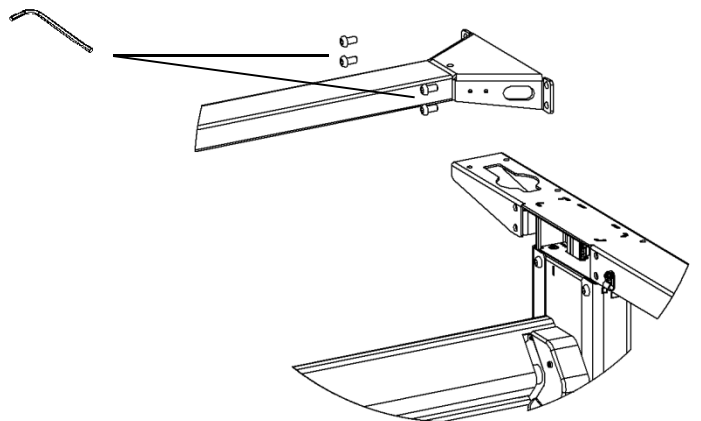
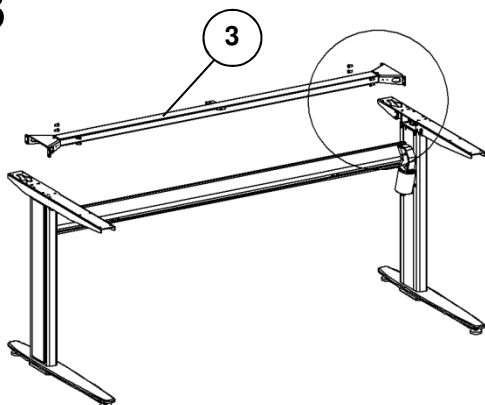

continued

continued

4

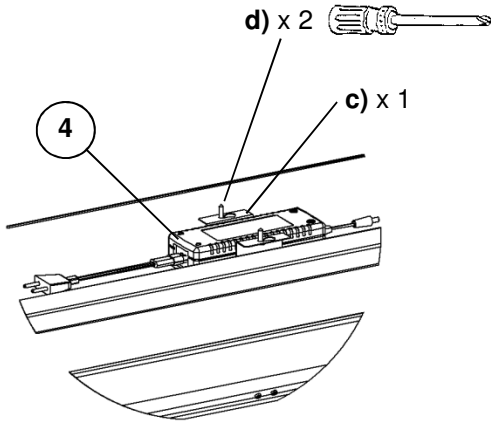

Run the wire with red plug from the control panel through these holes and connect to the power supply.

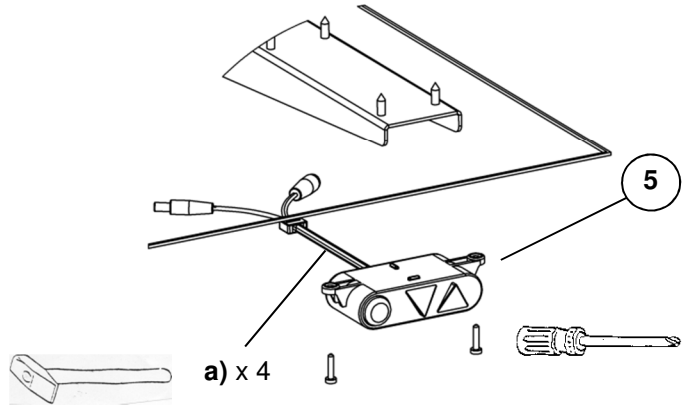
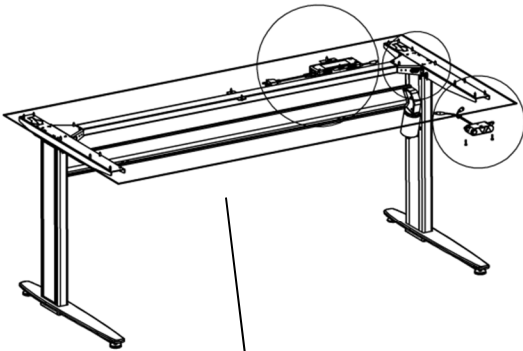
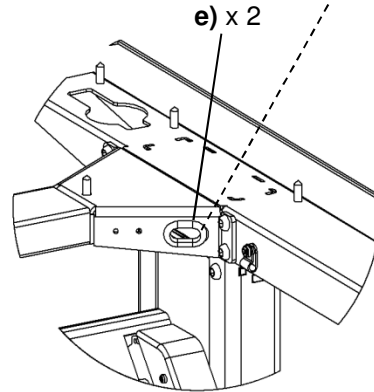

All screws **d)** need to be tightened to obtain optimal stability.

UP/DOWN operation:
Push button and UP or DOWN button must be pressed SIMULTANEOUSLY.

To ensure correct up and down operation of the desk frame it has to be fitted with a tabletop or applied a similar weight. Without a tabletop fitted, the desk frame may not operate in the downward direction.

The table is now assembled. Follow the directions for use in CHAPTER 2.

9. DECLARATION OF CONFORMITY

We hereby declare, under our sole responsibility that the following products:

- ConSet sit and stand frame product type 501-27

is in accordance with:

- Directive 2006/42/EF of The European Parliament and of the Council of 17 May 2006 on machinery and on changes of directive 95/16/EF

With reference to the above please be aware that:

- the sit and stand table is considered a machine and
- the sit and stand table may not be used until it has been assembled and installed according to the instructions

Manufacturer:

ConSet A/S
Industrivej 23
DK-6900 Skjern
Denmark
Tel: +45 9680 0080, Fax: +45 9680 0081
www.conset.com
conset@conset.com

www.PostureDepot.com



Posture Depot
179 Gasoline Alley, Ste. 203
Mooresville, NC 28117

T: 704-999-0809
E: info@posturedepot.com